

- Large housing
- AISI 304 stainless steel construction
- Wide range of accessories available
- Optional wiper and washer
- Weatherproof standard IP54

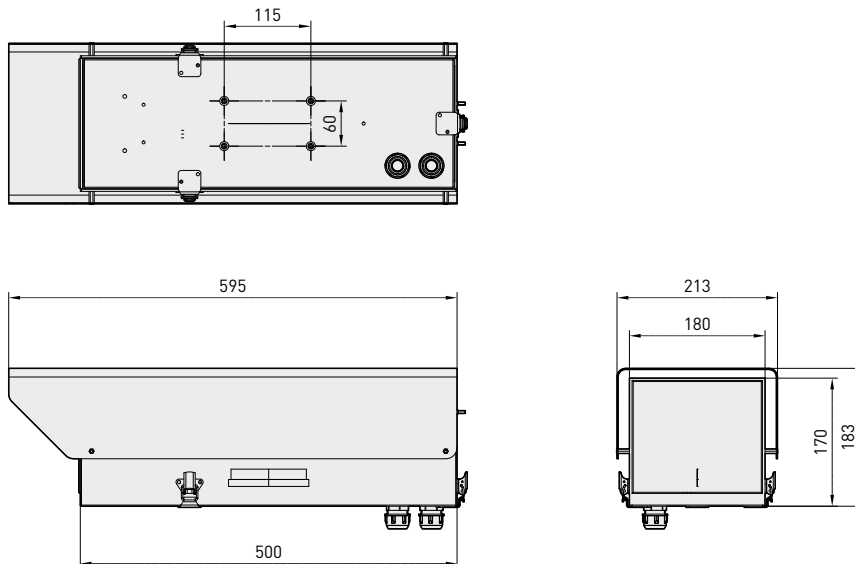

The NXJ housing, entirely made of AISI 304 stainless steel, has been designed to accommodate large cameras and zoom lenses. The NXJ housing has a frontal section of 180x170mm and is 500mm in length. It consists of a base with internal slide and a body which closes by means of three fastening clips.

The large window on the front makes it suitable for various zoom lenses. It is equipped with 2 PG16 cable glands for the connections and is pre-arranged for the bracket mounting and the wiper installation. A wide range of accessories is available, including heater, blower kit, camera power supply, stainless steel special brackets and possibility to mount the wiper and washer.



The values are in millimeters.

TECHNICAL DATA

NXJ				
Model	Sunshield	Heater 115/230V AC	Heater 12V DC/24V AC	Max consumption
NXJ1A000	•	•		40W
NXJ2A000	•		•	20W

GENERAL

Built in stainless steel AISI 304
 Epoxypolyester powder painted RAL9002 colour
 Opening / closure by means of three hinges

MECHANICAL

2 cable glands 2xPG16
 Glass window (BxH): 160x130mm (6.3x5.1in)
 External dimensions (BxHxL): 180x170x500mm (7x6.6x19.6in)
 Internal usable dimensions (BxH): 175x125mm (6.9x4.9in)
 Internal usable length: 490mm (19.3in)

Wiper

Wiper blade and enclosure made of AISI 316 stainless steel
 Dimensions (ØxL): 100x169mm (3.9x6.6in), not comprehensive of blade
 Connector 3+1 pins
 IN 230V AC, consumption 7W max
 IN 24V AC, consumption 7W max

ELECTRICAL

Heater Ton 15°C +/-3°C (59°F +/-5°F) Toff 22°C +/-3°C (71°F +/-5°F)

- IN 12V DC/24V AC, consumption 20W max
- IN 115/230V AC, consumption 40W max

Blower kit with thermostat air filter, Ton 35°C +/-3°C (95°F +/-5°F) Toff 20°C +/-3°C (71°F +/-5°F)

- IN 12V DC, consumption 4W max
- IN 24V AC, consumption 4W max
- IN 230V AC, consumption 4W max

Camera power supply

- IN 230V AC - OUT 12V DC, 50Hz, 400mA
- IN 230V AC - OUT 24V AC, 50Hz, 400mA

ACCESSORIES

ONXJVF1	Blower kit with thermostat air filter IN 12V DC
ONXJVF2	Blower kit with thermostat air filter IN 24V AC
ONXJVF3	Blower kit with thermostat air filter IN 230V AC
ONXJPS1	Camera power supply IN 230V AC - OUT 12V DC
ONXJPS2	Camera power supply IN 230V AC - OUT 24V AC

RELATED PRODUCTS

NXWBS1	Wall bracket for stainless steel housing
OPH200ADJB	Adapter kit for installation on NXPTH P&T
OMARPTH	Adapter kit for installation on PTH900 P&T
NXPTH	Stainless steel Pan&Tilt
PTH900	Aluminium Pan&Tilt
VIPNXJ1B	Wiper 230V AC
VIPNXJ2B	Wiper 24V AC
VIP5WAS01	Tank 5L, 230V AC washer pump
VIP5WAS02	Tank 5L, 24V AC washer pump
VIP25WAS01	Tank 25L, 230V AC washer pump
VIP25WAS02	Tank 25L, 24V AC washer pump
VIP25WASA01	Tank 25L, 230V AC washer pump, high delivery up 30m
DTWRX	Optional board for remote control of wiper and water pump of the UPTWAS series

ENVIRONMENT

Indoor / Outdoor
 Operating temperature: -20°C / +50°C (-4°F / +122°F)
 Salt-air fog resistance

COMPLIANCE TO

CE according to EN 61000-6-3, EN 60065, EN 50130-4
 IP54 according to EN 60529



Unit Weight:
 NXJ 9.6kg / 21.2lb
 VIPNXJ 1.5kg / 3.3lb

Package Weight:
 NXJ 10.2kg / 22.5lb
 VIPNXJ 1.7kg / 3.7lb

Package Dimensions (BxHxL):
 NXJ 24.5x24.5x62cm / 9.7x9.7x24.1in
 VIPNXJ 14.5x15x27cm / 5.7x5.9x10.6in

Master Carton:
 NXJ -
 VIPNXJ -