



Innovative and stylish housing, entirely built in technopolymer, and designed to simplify installation and servicing, the VERSO ensures total protection against all environmental conditions. Due to opening from its side, accessibility to the camera, lens and all its connections is made far easier.

Entirely manufactured from the newest, most resistant technopolymer, VERSO guarantees high impact resistance, weather protection from external agents and UV rays.

Its weatherproof features are ensured by the neoprene-rubber gaskets and the 2 PG9 and 1 PG11 cable glands or installed with an internal cable management bracket and optional sealing rings.

VERSO offers the possibility of various mounting options: wall mounted bracket, cable managed bracket, or on a Pan & Tilt head which includes the ability to house most combinations of cameras and lenses.

A specific version with a very efficient cooling system is available for installation with IP cameras and for high environmental temperature.

A wide range of accessories is available, including sunshield, heater kit, blower kit, camera power supply, heater fan-assistant or alarm tamper switch.

The accessories are supplied factory installed or as a simple upgrade kit.

- Indoor / Outdoor
- Entirely made of technopolymer (polycarbonate)
- Side opening, easy camera servicing
- Weatherproof standard IP66 (with cable glands or optional sealing rings)
- Good resistance to impacts
- Different mounting options: standard bracket or cable management bracket or P&T
- Patented



Mod. 016 - 017

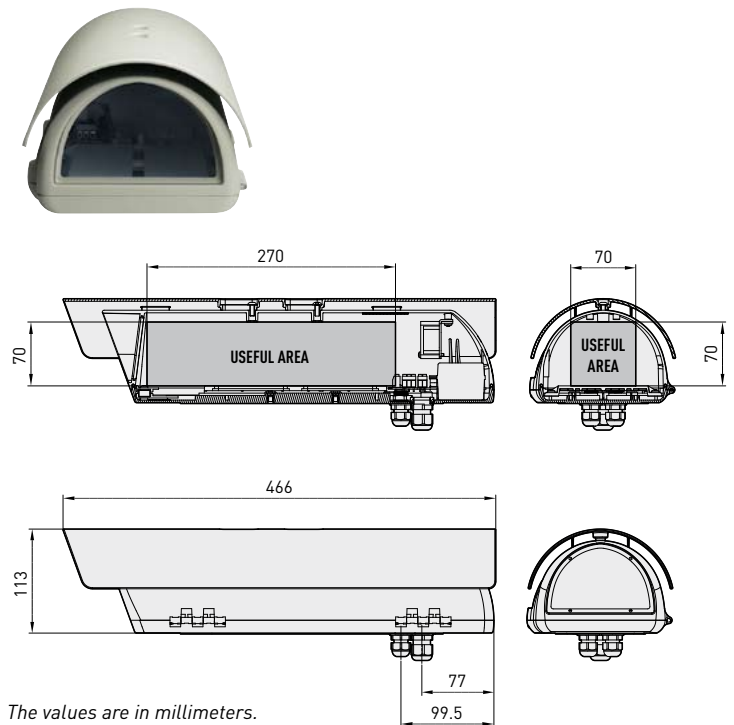

The values are in millimeters.

TECHNICAL DATA

VERSO							
Model	Sunshield	Heater 115/230V AC	Heater 12V DC/24V AC	Fan assisted heater 24V AC	12V DC blower with double air exchange filter	24V AC blower with double air exchange filter	Max consumption
HPV42D0A000							
HPV42K0A000	•						
HPV42K0A016	•					•	4W
HPV42K0A017	•				•		4W
HPV42K1A000	•	•					40W
HPV42K2A000	•		•				20W
HPV42K2A015	•			•			24W
HPV42K2A016	•		•			•	24W
HPV42K2A017	•		•		•		24W

GENERAL

Entirely made of technopolymer (polycarbonate)
 RAL9002 Colour
 Stainless steel external screws
 Supplied with instruction manual, desiccants bag, accessories for camera and lens mounting

MECHANICAL

3 removable cable glands: 2xPG9 and 1xPG11
 Polycarbonate window (BxH): 105x64mm (4.1x2.5in)
 Internal usable area (BxH): 70x70mm (2.7x2.7in)
 Internal usable length with and without accessories: 270mm (10.6in)

ELECTRICAL

Heater Ton 15°C+/-3°C (59°F +/-5°F) Toff 22°C+/-3°C (71°F +/-5°F)
 - IN 12V DC/24V AC, consumption 20W max
 - IN 115/230V AC, consumption 40W max

Heater fan assistant, continuous duty

- IN 12V DC, consumption 4W max
- IN 24V AC, consumption 4W max
- IN 100-240V AC, consumption 4W max, with wide range power supply IN 100-240V AC/12V DC

Blower kit with thermostat air filter, Ton 35°C+/-3°C (95°F+/-5°F) Toff 20°C+/-3°C (71°F+/-5°F) with wide range power supply IN 100-240V AC - OUT 12V DC

- IN 110-240V AC, consumption 4W max

Blower kit with thermostat Ton 35°C+/-3°C (95°F+/-5°F) Toff 20°C+/-3°C (71°F+/-5°F) for version with double filter

- IN 12V DC, consumption 4W max
- IN 24V AC, consumption 4W max

Camera power supply

- IN 100-240V AC - OUT 12V DC, 50/60 Hz, 1A
- IN 230V AC - OUT 24V AC, 50Hz, 400mA

ACCESSORIES

OHPVS42A000	Sunshield
OHPVH1	Heater 115/230V AC
OHPVH2	Heater 12V DC/24V AC
OHPVV1	Heater fan assistant, continuous duty IN 12V DC
OHPVV2	Heater fan assistant, continuous duty IN 24V AC
OHPVV3	Heater fan assistant, continuous duty IN 100-240V AC
OHPVCF3	Blower kit with thermostat air filter IN 110/240V AC
OHEPS19B	Wide range camera power supply IN 100-240V AC - OUT 12V DC
OHEPS20	Camera power supply IN 230V AC - OUT 24V AC
OHEGBPS1B	Wide range camera power supply IN 100-240V AC - OUT 12V DC in weatherproof box
OHEGBPS2B	Camera power supply IN 230V AC - OUT 24V AC in weatherproof box
OHPVIRA	Bracket for mounting 1 infrared illuminator (not compatible with double filter housing)
OHPVTA1	Tamper switch on board with tamper proof screws and key
OHEGBB	Weatherproof junction box, IP55

RELATED PRODUCTS

WBJA	Wall bracket with ball joint
WBOVA2	Wall bracket with internal cable channel
WBOV3A2	Wall bracket with internal cable channel, support plate and integrated junction box
WCM3A	Ceiling bracket with ball joint

WCM5A	Ceiling bracket with ball joint
WCM4A2	Ceiling bracket with internal cable channel
WFWCA	Column mount with ball joint
OWBIP1	Kit special gasket to allow protection IP66 for WBOVA2 and WCM4A2
PTH300	Pan&Tilt series
PTH900	Pan&Tilt series.

ENVIRONMENT

Indoor / Outdoor

Operating temperature with heater: -20°C / +50°C (-4°F / +122°F)

Very good resistance to the following chemical agents: basics, alcohols, gasses, hydrocarbon

Good resistance: organic and inorganic acids, oils

Low resistance: solvents

COMPLIANCE TO

CE according to EN61000-6-3, EN 60950, EN50130-4

IP66 according to EN 60529 with cable glands

IP66 according to EN 60529 with special gasket and bracket with internal cable channel

IP54 according to EN 60529 with bracket with internal cable channel

IP44 according to EN 60529 with double filter housing

V1 fire-self extinguish compliance according to UL94

Impact resistance IK10 according to EN 50102

SPARE PARTS LIST

DOTHPV01	Cable glands, gaskets and screws
OHPV42CS04	Complete upper body
OBKFIL	Replacement filter kit for double filter housing



Unit Weight:
HPV42K1 1.5kg / 3.3lb

Package Weight:
HPV42K1 1.8kg / 3.9lb

Package Dimension (BxHxL):
HPV42K1 16.5x6.5x49cm / 6.5x6.1x19.3in

Master Carton:
HPV42K1 10 units