

EXEHX4E ENCLOSURE

SPECIALTY, OUTDOOR, EXPLOSIONPROOF

Product Features

- Aluminum Construction
- Adjustable Mounting Cradle
- Use with Fixed Mount or Explosionproof Pan/Tilt
- For use in a Variety of Harsh and/or Hazardous Environments, including Marine Environments
- Meets NEMA Type 4X and IP66 Standards



EHX 4E ENCLOSURE



ENCLOSURE WITH SUN SHROUD

The **EXEHX4E** explosionproof camera enclosures are used in explosive and hazardous atmospheres throughout the world. They are designed to meet the rigorous requirements of explosionproof and dust-ignitionproof electrical equipment for installation and use in hazardous locations. These enclosures are also waterproof and dust tight.

Constructed of aluminum, enclosures in this series are available in 4-inch (10.16 cm), diameter to accommodate most camera and lens combinations. A unique camera mounting sled and track assembly allows fast, easy positioning of the camera and lens and can be securely locked in place.

Field-installed accessories include optional heater, blower and sun shroud.

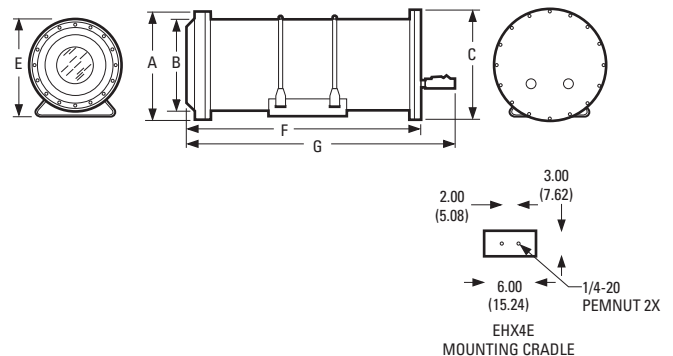

A	Ø7.00 (17.78)
B	Ø4.50 (11.43)
C	Ø7.00 (17.78)
D	Ø3.19 (8.10)
E	6.75 (17.15)
F	14.25 (36.20)
G	18.25 (46.36)
H	N/A

NOTE: VALUES IN PARENTHESES ARE CENTIMETERS; ALL OTHERS ARE INCHES.



International Standards
Organization Registered Firm;
ISO 9001 Quality System



TECHNICAL SPECIFICATIONS

EXEHX4E Explosionproof enclosure, 4" diameter x 12" L
(10.16 cm x 30.48 cm)

MECHANICAL

Cable Entry 2 explosionproof sealable fittings (supplied);
0.50-inch (1.27 cm) maximum inside diameter;
pipe plug supplied for possible unused gland in
rear plate

Front Window Fully tempered plate glass
4.25" (10.80 cm) diameter, 0.475" (1.21 cm) thick

Camera Mounting Adjustable sled

Maximum Camera
and Lens Size* *(Without Blower or Heater)*
2.75" H x 3.375" W x 12.00" L
(6.99 x 8.57 x 30.48 cm)
12.0" L x 3.0" diameter (30.48 x 7.62 cm)

GENERAL

Construction Aluminum, pipe 6061T6

Dimensions See dimension drawing on front page

Weight Unit Shipping

EXEHX4E 15 lb (6.79 kg) 19 lb (8.60 kg)

CERTIFICATIONS/RATINGS

- CE
- UL/cUL
- Classified by Underwriters Laboratories Inc. as to explosion and fire hazard only
- Type 4X enclosure for use in hazardous locations
- Class I, Groups C and D – Class II, Groups E, F, and G
- Class I, Zone 1, AEx d IIB, Ex d IIB
- Ⓧ 03 ATEX 0318166U
- 0539 Ⓧ II 2 G EEx d IIB
- Ⓧ II 2 D, IP 66
- Suitable for marine outside (saltwater) use, for vessels over 65 feet in length

RECOMMENDED MOUNTS

EM1109, EM2000, EM2200	Medium duty mount for horizontal/ vertical pipe or pole; maximum load 40 lb (18.1 kg)
EM22	Medium duty wall mount; maximum load 40 lb (18.1 kg)
MM22	Medium duty ceiling/pedestal mount; maximum load 40 lb (18.1 kg)

Adapters	AH2000	Adjustable head
	STI	Support strut

**Use with AH2000 adjustable head.

RECOMMENDED PAN/TILT

PT1260EX Series	Heavy duty explosionproof pan/tilt; maximum load 100 lb (45.4 kg)
-----------------	--

Distribuição: Segurança Industrial Equipamentos Ltda
fone/fax: (41) 4063-9687 ou 3287-1364
home page: www.segind.com.br
e-mail: cml@segind.com.br