

COMBUSTIBLE GAS DETECTOR



GD-1

SYSTEM PROTECTION FOR GAS HAZARDS

The GD-1 is an all electronic detector of toxic and combustible gases, specifically designed for connection to alarm control panels. It has a SPDT alarm relay, and a normally closed trouble relay. The GD-1 can operate on either 12 or 24 VDC power from standby or interruptible panel power.

The GD-1 has a three part plastic case that allows the unit to mount flat to a wall or to mount over and become the cover of an electrical box. The box may be a single gang electric box, two gang old work box, or a four inch square box. The unit has a terminal block for connections to the control panel.

The GD-1 uses a full wave bridge rectifier at its power input, so that it is independent of the polarity of the input power. It can operate on DC or AC voltages between 10 and 26 volts. A switching regulator is used to efficiently match the wide input voltage range to the fixed, internal power system. As a result the power consumption is fairly constant at about .75 watts.

The GD-1 has an internal 2 minute time delay, that prevents alarms during the warm-up of the gas sensor. During the warm-up period the green LED blinks on and off. Once the delay is over, the continuous green light indicates normal operation. This green LED is part of a supervisory circuit of critical functions in the detector.

The red LED turns on at the same time the alarm relay switches, to show the alarm condition. The trouble relay is normally closed. The relays are reed type devices that are sealed, thus are inherently explosion proof.

In the configuration, as shipped from the factory, the GD-1 is self-restoring. When the air clears of gas, the red light will turn off and the relays switch back to their normal states. There is a jumper wire on the circuit board, that can be clipped to cause the unit to latch in upon alarm. Once latched in, power will need to be interrupted to un-latch the alarm condition.

The alarm set point is factory calibrated at 20% of LEL of natural (methane) gas. LEL (Lower Explosive Level) is the lowest level of a mixture of gas and air that can be explosive. The alarm point on propane, butane and LP gas is not factory set, but is approximately 20% of LEL.

Other flammable gases can be detected by the GD-1. See the list on the other side. The GD-1 does **NOT** detect carbon monoxide.

- DETECTS ALL HEATING GASES: NATURAL (METHANE), BUTANE, PROPANE, AND LP GAS.
- EXPLOSION PROOF DESIGN.
- SPDT ALARM RELAY
- CAN BE SELF-RESTORING OR LATCHING.
- CONNECTS TO CLASS A OR CLASS B PANELS.
- TEMPERATURE COMPENSATED.
- SIMPLE INSTALLATION AND OPERATION.
- FAIL SAFE SYSTEM: SUPERVISED SENSOR.
- SPECIAL CALIBRATIONS AVAILABLE.
- GAS DETECTION IS FIRE PREVENTION.
- N.C. TROUBLE RELAY

SPECIFICATIONS

SIZE: 4 ½ x 5 x 1 ½ inches

SHIPPING WEIGHT: One pound

VOLTAGE: 10 TO 26 VAC or VDC

CURRENT: 60 ma @ 12 VDC
30 ma @ 24 VDC

COLOR: White

SENSOR MAINTENANCE: Not required

ALARM RELAY RATING: 0.2 Amps, 100V, 3VA

TROUBLE RELAY : 0.50 Amps, 200 Volts, 10 VA

OPERATING TEMPERATURE RANGE: 0° to 150° F

ALARM SET POINT: 20% of LEL of Natural Gas



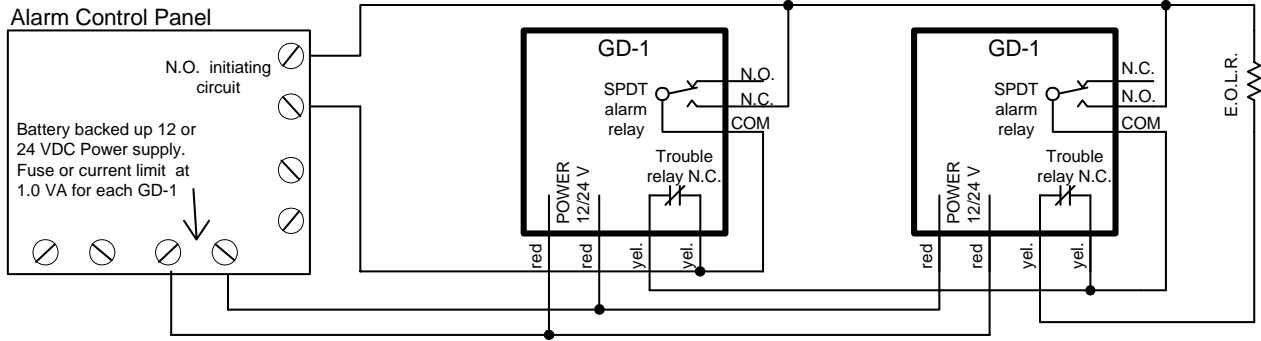

NOTE:

1. The GD-1 is for use with Alarm Control Panels that have 12 to 24 Vdc power and 12 to 24 Vdc alarm initiating circuits.
2. The GD-1 is intended for installation in buildings in non-hazardous locations such as residences, retail stores, office buildings, and institutional buildings.
3. The GD-1 is NOT intended for use in industrial applications such as refineries, chemical plants, etc.
4. LOCATION: If the gas used is natural gas (methane) mount the GD-1 on a wall about one foot down from the ceiling. If the gas used is propane (LP), mount the GD-1 on a wall or column, one foot above the floor. Do NOT mount the GD-1 in a corner.
5. SPACING: Use the same spacing as for smoke detectors-- 30 foot centers, 900 square feet per detector.
6. INSTALLATION
 The GD-1 Gas Detector mounts on a two gang, old work box or a 4 X 4 electrical box, provided by the installer. The GD-1 has terminal connections.
 A GD-1 is usually located in each room (except kitchens or bathrooms) where gas appliances are located.
 A GD-1 is usually located in each room through which gas pipes pass.
7. The alarm control panel zone inputs must be terminated with end of line resistors (E.O.L.R.), that are provided with the panel.
8. When using the GD-1 with normally closed initiating circuits, use the Com. and N.C. alarm relay connections.

THE GD-1 MAY BE USED ALONE

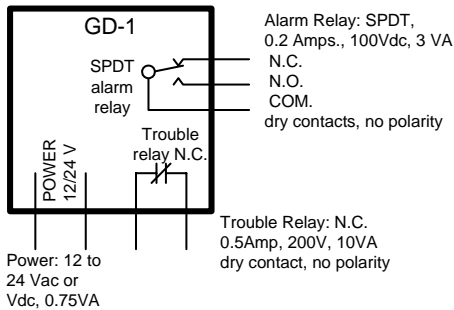

GD-1 CONTROLLING A REMOTE ALARM

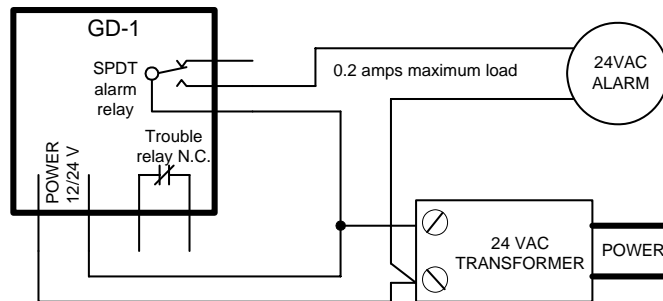

THE FOLLOWING IS A LIST OF GASES THE GD-1 CAN BE CALIBRATED TO DETECT.

- | | | | | | |
|----------------|------------------|-----------------|--------------|----------|---------|
| *ACETYLENE | ALCOHOL | BENZENE | *BUTANE | ETHANE | ETHANOL |
| ETHYLENE | ETHYLENE OXIDE | *GASOLINE FUMES | JET FUEL | | |
| KEROSENE FUMES | *LACQUER THINNER | *LP GAS | *METHANE GAS | | |
| METHANOL | MEK | *NATURAL GAS | PENTANE | *PROPANE | XYLENES |

*Standard GD-1 calibration from the factory will detect these gases. Others require special calibration with extra charge.