

# ROTATING BEACONS EExd(e), Weatherproof XB5 & TH5 Ranges



## Introduction

These certified rotating beacons have been designed for use in flammable atmospheres and harsh environmental conditions. The marine grade alloy enclosures are suitable for use offshore or onshore, where light weight combined with corrosion resistance and strength is required. Units can be painted to customer specification and fitted with identification labels.

There are two models available,

- (1) standard rotating mirror with tungsten halogen bulb.
- (2) sequenced flashing xenon tubes.

Both models are available with optional EExe terminal chamber.

- ★ Zone 1 use.
- ★ EExde IIBT4/T6.
- ★ ATEX approved Ex II 2G.
- ★ BASEEFA certified.
- ★ Certified temperature  $-20^{\circ}\text{C}$  to  $+55^{\circ}\text{C}^*$ .
- ★ IP66, IP67 and IP68.
- ★ Corrosion Resistant.
- ★ EExde version has gland earth continuity in the GRP terminal chamber.
- ★ Optional guard.
- ★ Retained cover screws.
- ★ Various lens colours.

\*Model dependent.

Distribuição: Segurança Industrial Equipamentos  
Fone/Fax: (41) 4063-9687 ou 3287-1364  
cml@segind.com.br - segindbr@hotmail.com  
www.segind.com.br

# Specification

## Model: XB5 Sequenced flashing xenon tubes.

Voltage	DC			AC 50/60 Hz				
	24	48	110	110	120	220	240	254
Tube Energy (Joules)	5	5	5	5	5	5	5	5
Peak Current Consumption (mA)	1300	650	300	500	450	240	230	210
Effective Intensity (Cd)	86	86	86	86	86	86	86	86
Peak Intensity (Cd)	45683	45683	45683	45683	45683	45683	45683	45683

NOTE: The above figures (Cd) are for a clear lens @ 1Hz flash rate.\*

## Model: TH5 Rotating Mirror.

Wattage	55W	70W	70W	70W	70W
Voltage	12d.c	24d.c.	110a.c.	220a.c.	240a.c.
Peak Current Consumption (A)	4.58	2.92	0.64	0.31	0.34

Rotational Speed (rpm)	60	120	180
Effective Intensity (Cd)	3354	1957	895
Peak Intensity (Cd)	11164	11164	11164

Note: The above figures (Cd) are for a 70W lamp with clear lens.

The photometric data given above has been verified by BSI. Reports are available if required.

Terminals: EExe: 6 off suitable for up to 6mm<sup>2</sup> cable.  
EExd: 6 off suitable for up to 6mm<sup>2</sup> cable.

Entries: Up to 3 x 20mm ISO or 2 x 25mm ISO in EExd unit.  
Up to 4 x 20mm ISO or 4 x 25mm ISO in EExe unit.

Materials: LM25 TF marine grade alloy body.  
Glass reinforced polyester (GRP) terminal chamber.  
Toughened Wellglass.

Ingress Protection: IP66, IP67 and IP68.

Weight: XB5 14.6Kg; TH5 14.9Kg. Add 1Kg for EExde versions.

Finish: Epoxy paint finish as standard or to customer's specification.

Certification: CENELEC - EN50014, EN50018, EN50019.  
Certificate No. Baseefa02ATEX0225X.  
BASEEFA - EExd IIB T4/T6 or EExde IIB T4/T6.

Certified Temperature: -20°C to +55°C (TH5) -20°C to +40°C (XB5).

Life: We do not recommend the continuous use of the TH5 for over 3 hours as this could adversely affect its life.

Rotational speed (TH5) may vary by ±20% of stated R.P.M.

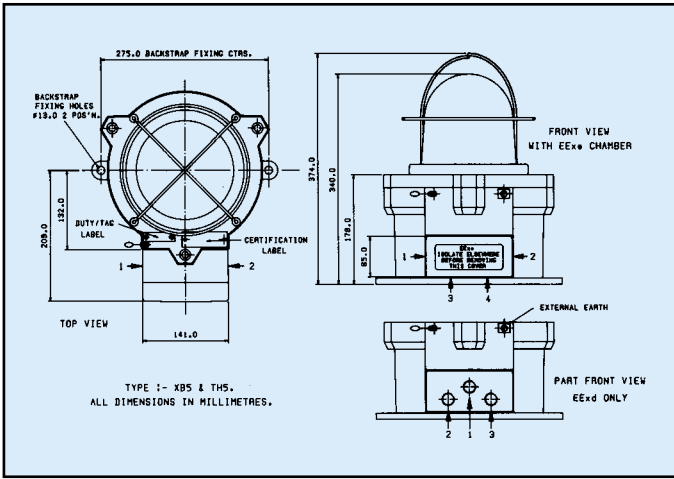

### TEMPERATURE RATINGS

TYPE	voltage/wattage	T CLASS	AMB.
XB5	DC Units	T6	40°C
	AC Units	T6	40°C
TH5	DC Units	T4	55°C
	AC Units	T4	55°C

### \* FOR COLOURED LENSES

Colour	Red	Blue	Amber	Green	Yellow
Multiplying Factor (Approximate)	0.15	0.12	0.51	0.49	0.86

## Ordering Requirements:

The following code is designed to help in selection of the correct unit. Build up the reference number by inserting the code for each component into the appropriate box.

Model	Rotational Speed (TH5 only)	Terminal Chamber	Voltage	Entries	Lens Colour	Tag Label	Guard	Finish
Model XB5 TH5	Rotational Speed 60 r.p.m. 1 120 r.p.m. 2 *180 r.p.m. 3 *Not available 110V	Terminal Chamber EExd D EExde E	Voltage 12VDC A 24VDC B 48VDC (not TH5) C 110VDC (not TH5) D 110VAC E 120VAC (not TH5) F 220VAC G 240VAC H 254VAC (not TH5) J	Entries 20mm *B 25mm *C *Prefix entry size (see diagram above) with entry position code. e.g. 1B, 2B.	Colour Red R Blue B Green G Yellow Y Amber A Clear C	Label None N Yes Y (Please specify wording)	Guard None 0 Guard 1	Colour Red R Grey G Blue B Yellow Y White W Other S (Please specify)