

GV-HOU3512

IP66 INDOOR/OUTDOOR HOUSING

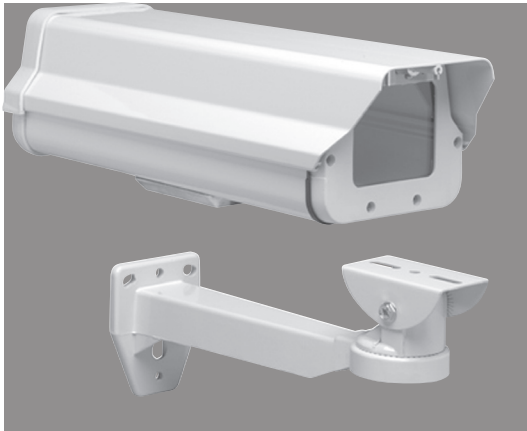

SPECIFICATIONS

Viewing Material: Plate Glass 5mm, 0.2"
Construction: Extruded Aluminum
Cable Entry: Gland fitting on bottom of housing
Latch: Located at rear of housing. Accepts padlock for security
Camera Mounting: Removable camera sled
Weight: 3.52kg, 7.76lbs
Dimensions: (D) 390mm, 15.35" x (W) 140mm, 5.51" x (H) 115mm, 4.53"
Maximum Camera Size (D) 240mm, 9.45" x (W) 105mm, 4.13" x (H) 80mm, 3.15"
Bracket: GV-Bracket, Metal Bracket for GV-HOU3512HB
Material: Aluminum
Length: 240mm (9.45")
Max Load: 10kg
Swivel Angle: 360°
Tilt Angle: -80° ~ +45°

SUMMARY

This low cost IP66 housing is designed as a medium sized environmental enclosure. It can accommodate all CCD cameras with a length no greater than 9". Constructed of extruded aluminum and equipped with a hinged, latching cover, this housing serves well for general surveillance applications.

Equipped with a removable sled the cameras can be set up, adjusted and then re-mounted in the housing. The front cover hinge makes adjustment and service to the camera very accessible.

FEATURES

- Indoor/Outdoor applications - IP66
- Adjustable position bracket mount
- Extruded Aluminum Construction
- Gasket protected cover
- Stainless Steel Latch
- Glass window

