

# EXPT-EXPTD EEX PAN & TILT WITH CAMERA HOUSING



- Absence of external wiring in rotation
- Explosion-proof certified
- Indoor and outdoor installations
- Baked-on enamel RAL7032 colour
- Wide range of accessories
- Weatherproof standard IP65

The EXPT system includes a housing with the same characteristics of the EXH and a Pan & Tilt, designed for movement both in horizontal and vertical planes. The peculiar characteristic of the EXPT device is the absence of external wiring in rotation, either for the control of the Pan & Tilt or for the camera and lens. This solution makes the installation and the maintenance of the Pan & Tilt easy.

The EXPT includes one multiconductors cable that comes out from the base of the Pan & Tilt through a cable-gland. The EXPT is supplied with preset and housing heater. The EXPT can be equipped with sunshield, autopan, reinforced housing heater and motors heater, and patented glass protection device (model EXPTD).

The glass protection device consists of a connection flange with the housing, a closing flange and an explosion-proof central body containing a rugged and transparent glass, a continuous current motor powered in 24VAC, two windings and a transparent Mylar film, installed just in front of the glass. The motor drives the winding for recovering the dirty Mylar film, while at the

same time the other winding installed on the opposite side releases the clean film. The transparent Mylar film allows about 350 shifting steps. When the film is dirty, the operator will activate the motor shifting the film to obtain a clean camera picture. The end of the Mylar film will be indicated to the operator through marks printed on the last 50 cm of the film.

The EXPT Pan & Tilt's with integrated housing are made of strong anticorodal aluminium alloy and baked-on enamelled with a RAL7032 colour. The range is manufactured according to II 2 GD EEx d IIC T6 or II 2 GD EEx d IIB+H2 T6. The range is ATEX certified, for installation in potentially explosive areas.

### EXPTWB

Bracket for EXPT, constructed in solid, anticorodal aluminium alloy, color RAL7032. It is particularly suitable for external applications. It can support a maximum non-static weight of 100 kg.

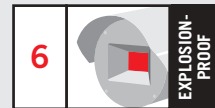

MODELS									
	Certification IIB	Certification IIB+H2	Certification IIC	Housing heater	Pre-wired multipolar cable	PRESET	AUTOPAN	Glass protection device	Reinforced heater and P&T heater
EXPTC000	•	•	•	•	•	•			
EXPTC010	•	•	•	•	•	•	•		
EXPTC033R	•	•	•		•	•	•		•
EXPTD001	•	•		•	•	•		•	
EXPTD011	•	•		•	•	•	•	•	
EXPTD035R	•	•			•	•	•	•	•



## EXPTC

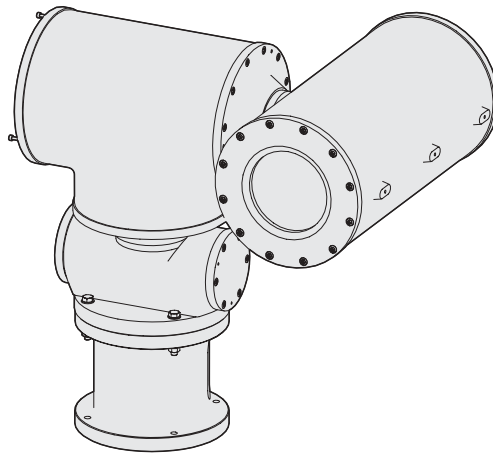
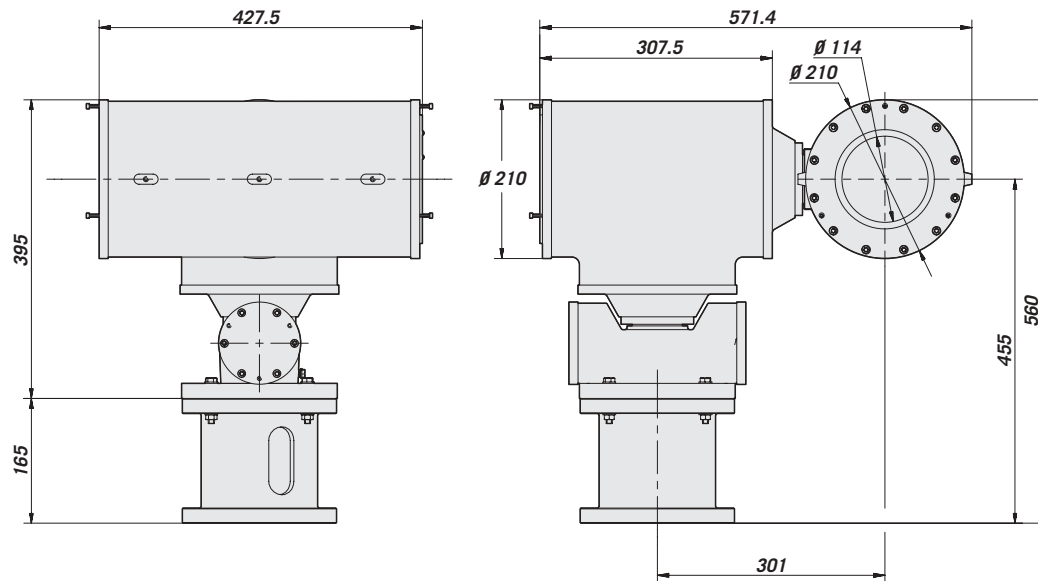

## EXPTWB

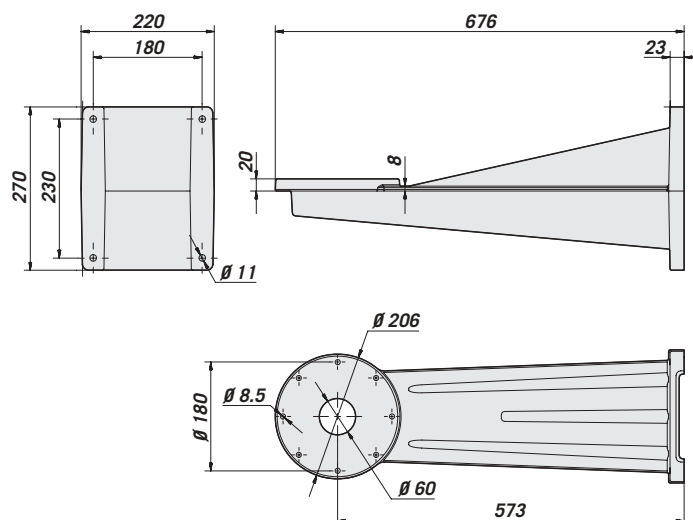

The values are in millimeters.

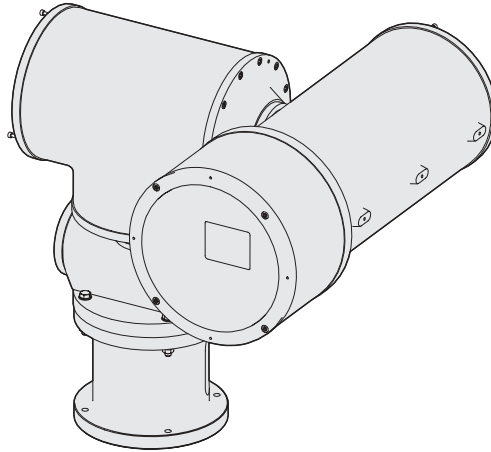
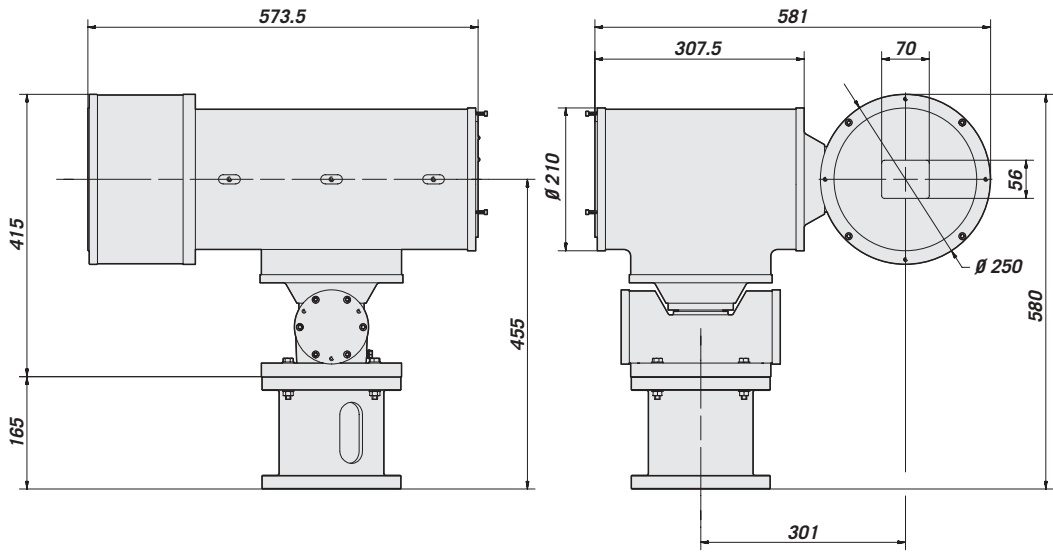
**EXPTD**

The values are in millimeters.



## TECHNICAL DATA

### GENERAL

#### EXPT - EXPTD

- Non-corrosive die-cast aluminium (anticorrosive)
- Epoxy polyester powder painted RAL7032 colour
- Painted with plast-coat for low temperature, blue color (mod. EXPTC033R and EXPTD035R). Plast-coat is resistant to stress cracking, adverse weather conditions, detergents, salt-spray and typical airborne pollutants
- Supplied with: instruction manual and conformity declaration

#### EXPTWB

- Made of strong non-corrosive aluminium alloy (anticorrosive)
- Epoxy polyester powder painted RAL7032 colour
- Painted with plast-coat (mod. EXPTWB00R), blue color

### MECHANICAL

- 0-360° horizontal movement, 6° degree/sec
- +/-90° vertical movement, 2,4° degree/sec
- Horizontal Torque: 2,5 kgm
- Vertical torque: 6 kgm
- Horizontal vertical limit switch adjustable through preset
- 1 cable gland 3/4" GAS at the base of the P&T
- One multiconductors armoured cable normally supplied 7,5 m (24ft) length: 25 poles 0,5 mm, 4 poles 1 mm, 2 RG174 of 75 W

#### External dimensions (ØxL):

EXPTC	570x407x640 mm (22.4x16x25.1 in)
EXPTD	580x575x580 mm (22.8x22.6x22.8 in)

#### Internal dimensions (ØxL):

EXPTC	Ø 180x380 mm (7x14.9 in)
EXHD	Ø 180x460mm (7x 18.1 in)

#### Internal usable area (WxHxL):

EXPTC	100x100x280 mm (3.9x3.9x11 in)
EXPTD	100x100x360 mm (3.9x3.9x14.1 in)

#### Window (WxH):

EXPTC	Ø 114 mm (4.48 in)
EXPTD	70x53 mm (2.7x2 in)

#### EXPTD

- Mylar film 80 mm (3.1 in) wide and 18 m (59 ft) length, 350 shifting steps, marks printed on the last 50 cm (19 in)
- Glass protection device Ø 250x140 mm (9.8x5.5 in)

#### EXPTWB

- Wall mount
- Load rating: 100 kg (220 lb)
- Length: 676 mm (26.6 in)

### ELECTRICAL

- Power supply IN 24VAC, 50/60Hz
- Horizontal and vertical motor consumption: 50W
- Standard vertical and horizontal preset potentiometers
- Housing heater IN 24VAC, 20W, Ton 10°C +/- 4°C (50°F) Toff 25 °C +/- 3°C (77°F)
- Glass protection device IN 24VAC, 2W (EXPTD only)
- Housing reinforced heater and P&T heater (three resistors in the housing and two resistors, one for each motor, in the P&T): same features of the standard heater, each resistor 20W

### INSTALLABLE DEVICES

- Camera equipped with lens for a maximum power of max 20 W, input power supply max 240VAC.

⚠ *NOTE: camera housing power supply must always be carried with input power supply of 24VAC.*

### ACCESSORIES

EXPTS000	650 mm (25.6 in) housing sunshield (EXPTC000)
EXPTS001	760 mm (29.9 in) sunshield for housing with glass protection device (EXPTD001)

### RELATED PRODUCTS

EXPTWB000	P&T bracket
-----------	-------------

### ENVIRONMENT

- Indoor/outdoor
- Operating temperature:  
EXPTC and EXPTD: -20°C up to + 50°C (-4°F up to 122°F)  
EXPTC033R and EXPTD035R : -30°C up to + 50°C (-22°F up to 122°F)

### COMPLIANCE TO

According to the directive 94/9/CE Atex (certification released by TÜV Nord):

- Group: II (Surface device )
- Category: 2 (elevated protection degree, the devices of this category can be installed in zone 1 and 21 and in zone 2 and 22)
- Atmosphere: G D (gas and dust)
- EEx: explosion-proof
- d: explosion proof housing
- IIC: group protection
- T6 T85°C: temperature classification (gas and dust respectively)

#### EXPTC000 - EXPTC010 - EXPTC033R:

- Ⓜ II 2 GD EExd IIC T6 T85°C
- Ⓞ 0032 according to 94/9/CE Atex
- IP65

#### EXPTD001 - EXPTD011 - EXPTD035R:

- Ⓜ II 2 GD EExd IIB+H2 T6 T85°C
- Ⓞ 0032 according to 94/9/CE Atex
- IP65

### SPARE PARTS LIST

OEXMYLAR	Mylar film replacement kit, L 18 m (59 ft) 350 steps
OEXVET	Front flange complete with glass for EXPTC000
OEXDPV	Front flange complete with glass protection device for EXPTD001
OSLIEX	Internal slide complete with heater for integrated housing EXPTC
OSLIEXD	Internal slide complete with heater for integrated housing EXPTD



#### Unit Weight (kg / lb):

EXPTC:	55 / 121.2
EXPTD:	62,6 / 138
EXPTWB:	11 / 24.2

#### Package Weight (kg / lb):

EXPTC:	61 / 134.5
EXPTD:	
EXPTWB:	

#### Package Dimensions (cm / in):

EXPTC:	78x37x67 / 30.7x14.5x26.3
EXPTD:	
EXPTWB:	

#### Master Carton (units):

EXPTC:	
EXPTD:	
EXPTWB:	