



# DNH

HEAD OFFICE, NORWAY  
DNH AS

Phone..... + 47 35 98 56 00  
Fax..... + 47 35 98 56 10  
E-mail..... dnh@dnh.no  
Web-Site..... www.dnh.no

ENGLAND  
DNH WW Ltd  
Phone..... + 44 1908 275 000  
Fax..... + 44 1908 275 100  
E-mail..... dnh@dnh.co.uk

GERMANY  
DNH GmbH  
Phone... + 49 040 6569 30-0  
Fax..... + 49 040 6569 30-30  
E-mail..... dnh@dnh.de

USA  
DNH Speakers Inc  
Phone..... + 1 484 494 5790  
Fax..... + 1 484 494 5793  
E-mail..... dnh@dnhspeakers.com

## DSP-25EExmN(T)

ISO 9001 CERTIFIED

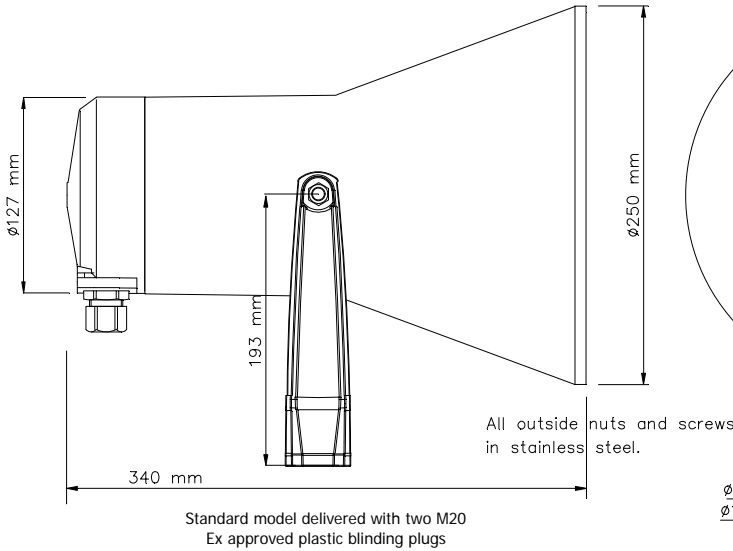

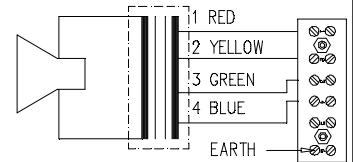

CIRCUIT DIAGRAM

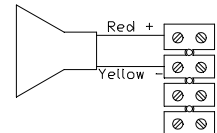

100V line Primary nominal tapings	
1 : 2	25,0 W
2 : 3	12,5 W
3 : 4	6,0 W
1 : 3	4,0 W
2 : 4	2,0 W
1 : 4	1,0 W

Low impedance



Certified by / Certification code / Number: NEMKO / Ex d e mb IIB+H<sub>2</sub>/IIC T5 Gb / 10ATEX1053  II 2G

Sound pressure levels at 1W/1m

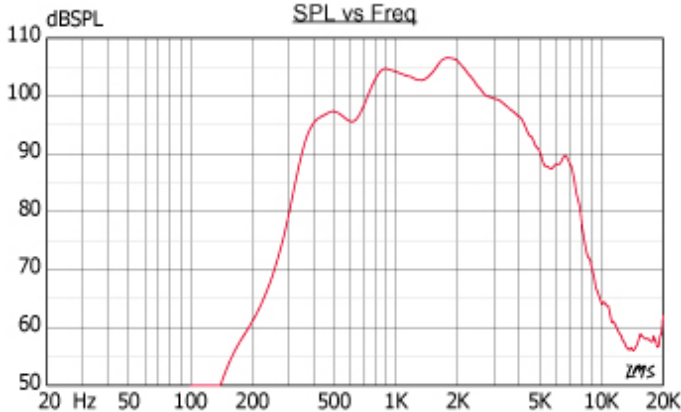

Specifications

Specifications	IIB	IIC
Material / Color	Anti-static polyamide / Black	
Mounting	Bracket	
Termination	e-chamber, screw terminals	
Weight w/transformer	4,0 kg	
IP-rating (e-chamber)	66	
Max. / min. amb. temp	55°C / -53°C	
Rated / max. power	25 W / 25 W	
SPL 1W/1m	106 dB	102 dB
SPL rated power	117 dB	113 dB
Effective freq. range	370 – 7000 Hz	400-7000
Dispersion (-6dB) 1kHz / 4kHz	98° / 29°	100° / 30°
Directivity factor, Q 1kHz	3,7	
Options	Impedances, labels	

### Installation, Operation and Maintenance Procedures

- Remove lid by one screw, lead cable through the cable gland and connect to terminal with required tapping.
- Screw lid back into place by one screw with a torque of 2Nm to assure the IP rating.
- Fasten bracket with one to three screws.
- To change the position of the loudspeaker, please adjust the standard U- bracket (by loosening / tightening the screws) as required.
- Use only certified/specified cable glands and blinding plugs, reflecting the same IP rating and temperature range as the loudspeaker.
- Standard model delivered with two M20 Ex approved plastic blinding plugs.
- For optimum performance, always use the correct voltage / power and operate within the frequency limits as stated.
- Do not open loudspeaker when energized.
- This loudspeaker is supplied with a two years warranty against defective workmanship.

DNH reserves the right to alter specifications without notice

