

F220 Series

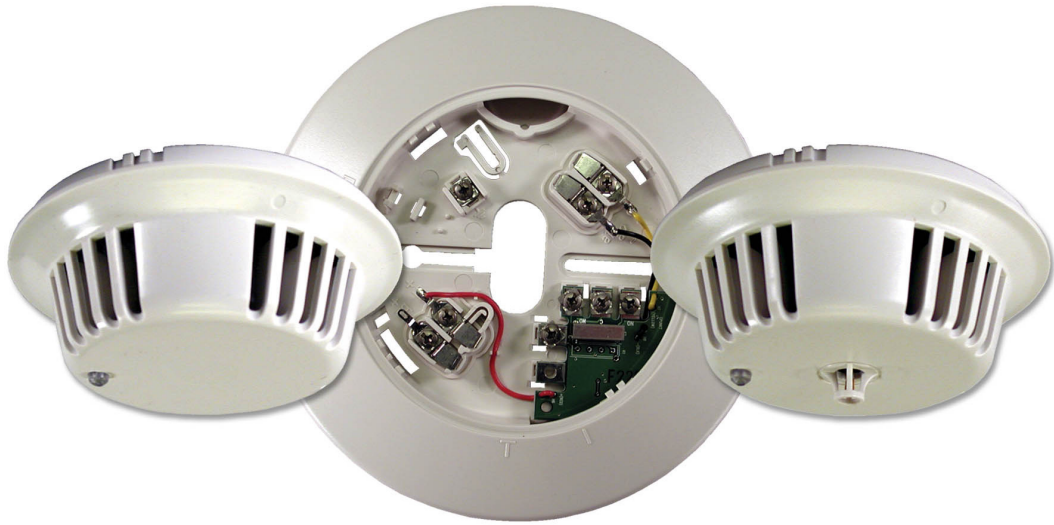

Security Systems

EN | Installation Instructions
Photoelectric Smoke/Heat
Detectors

BOSCH

1.0 General Information

1.1 F220-B6 Series Bases

Use with the F220 Series Heat and Photoelectric Smoke Detectors. Install them in accordance with NFPA 72, The National Fire Alarm Code.



For proper system installation, read and understand NFPA-72, The National Fire Alarm Code before installation.

This document covers mounting, wiring, power requirements, testing, and maintenance for the bases and detectors:

- For two-wire compatibility information see the *Technical Service Note* (P/N: 4998148185).
- For installation guidelines see the *Technical Service Note* (P/N: 26715).

1.2 Detector Features

Figure 1: F220 Series features

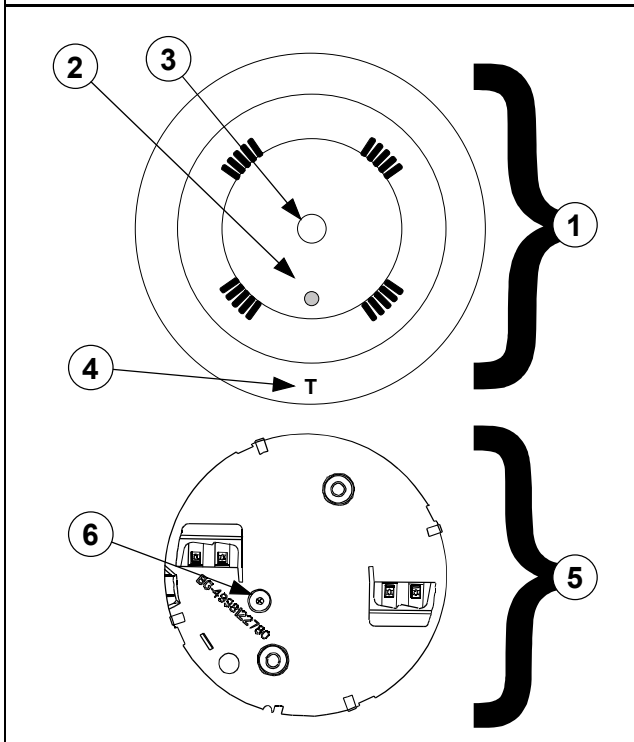

- 1 - Detector front
- 2 - LED
- 3 - Thermistor
- 4 - "T" mark
- 5 - Detector back
- 6 - ChamberMaid™ location

1.3 F220 -135/135F/190F Electronic Rate-of-Rise/Fixed Temperature Heat Detectors

Table 1: Color coding for heat detectors

F220-135/135F	A gray circle around the thermistor.
F220-190F	A black circle around the thermistor.

Use with F220 Series bases to provide general property protection.



The F220-135, F220-135F and F220-190F are not life safety devices.

1.4 F220-P/-PTH/-PC/-PTHC Photoelectric Smoke Detectors

The F220P Series Detectors are UL Listed, open-area photoelectric smoke detectors that work with commercial fire protective signaling systems and household fire warning systems. Select the appropriate mounting base to configure the detectors for two-wire or four-wire versions.

For commercial and industrial installations, 30 ft (9.14 m) spacing between detectors is recommended.

To verify power to the detector and a functioning smoke sampling circuitry, a dual color LED indicator flashes green every eight seconds when operating normally. It flashes once every four seconds when a trouble condition exists.

If the detector finds an alarm condition, the LED changes from flashing green to steady red. The detector returns to normal when power is interrupted and the alarm condition clears.

Throughout its normal life cycle, the smoke detector monitors and periodically readjusts itself to keep the sensitivity at its factory calibrated level. When excessively dirty, the detector's LED flash rate changes from an eight second flash rate to a four second rate. If CleanMe™ is selected, the detector transmits a CleanMe signal to the compatible control panel to indicate a dirty smoke detector.

See *Section 1.5 CleanMe toggle* to enable CleanMe.

1.5 CleanMe toggle

To activate the CleanMe feature:

1. Place a magnet next to the "T" marked on the detector base for more than one red LED flash but less than three red LED flashes. The LED flashes green one time and proceeds into the first of two sensitivity reading displays.

2. When the LED flashes red, place the magnet near the “T” again.
3. Hold the magnet against the “T” on the detector base until the green LED flashes twice and the red LED repeats the sensitivity indication. This turns on the CleanMe feature.
4. The LED flash sequence is as follows:
 - a. single flash green LED
 - b. double flash green LED
5. To disable CleanMe, repeat this process and verify the double flash returns to a single flash.

1.6 Magnet operation/sensitivity mode

The F220P Series Detectors feature a unique magnet operation/sensitivity test. Test the detector by placing the magnet next to the “T” marked on the detector base for three consecutive flashes to cause an alarm. If the magnet is there for less than three flashes and more than one flash, the detector goes into Sensitivity Mode. *Table 2* describes the different LED flash rates for the Sensitivity Mode.

# of Red Flashes	Definition
1	Malfunctioning smoke or heat detector
3	Normally operating smoke or heat detector with little or no dirt contamination
4 to 6	Progressively more contamination
7 to 10	Trouble condition, very dirty but still compensated to 3%. < 3% at 10 flashes.
11	< 2.5%/ft (2.5%/0.3 m)
12	< 2.0%/ft (2.0%/0.3 m), chance of false alarm increased
13	< 1.5%/ft (1.5%/0.3 m)
14	< 1.0%/ft (1.0%/0.3 m), chance of false alarm greatly increased
15	< 0.5%/ft (0.5%/0.3 m), false alarm very likely

1.6.1 The LED sensitivity flash procedure

1. Briefly place the magnet at the “T” on the detector base for at least one red LED flash but less than three LED flashes.
2. Wait for the first single green LED flash.
3. Count the number of red LED flashes that follow. This indicates the sensitivity.

1.6.2 Normal sensitivity LED flash example (see Figure 2)

1. Enter Sensitivity Mode on the smoke detector.
2. The LED flash sequence is as follows:
 - a. three red LED flashes
 - b. a single green LED flash (a separator)
 - c. three red LED flashes
 - d. a single green LED flash.
3. The detector exits sensitivity mode and returns to one green LED flash every eight seconds.

Figure 2: LED flashes for normal operation

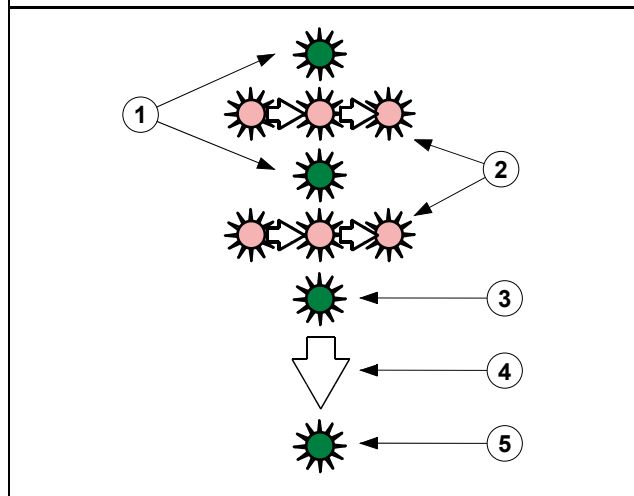

- 1 - Green LED flash
- 2 - Sequence of three red LED flashes
- 3 - Green LED flash to leave sensitivity mode
- 4 - 8 seconds later
- 5 - Green LED flash to return to normal operation

1.6.3 Normal CleanMe sensitivity LED flash procedure

1. Briefly place the magnet at the “T” on the detector base for at least one red LED flash but less than three red LED flashes.
2. Wait for the LED to flash green three times.
3. Count the number of red LED flashes that follow. This indicates the sensitivity.

1.6.4 The CleanMe sensitivity LED flash example

1. Enter Sensitivity Mode on the smoke detector.
2. The LED flash sequence is as follows:
 - a. three red LED flashes
 - b. three green LED flashes (a separator)
 - c. three red LED flashes
 - d. two green LED flashes.
3. The detector exits the sensitivity mode and shows two green LED flashes every eight seconds.

Figure 3: Normal Sensitivity example of LED flashes for CleanMe

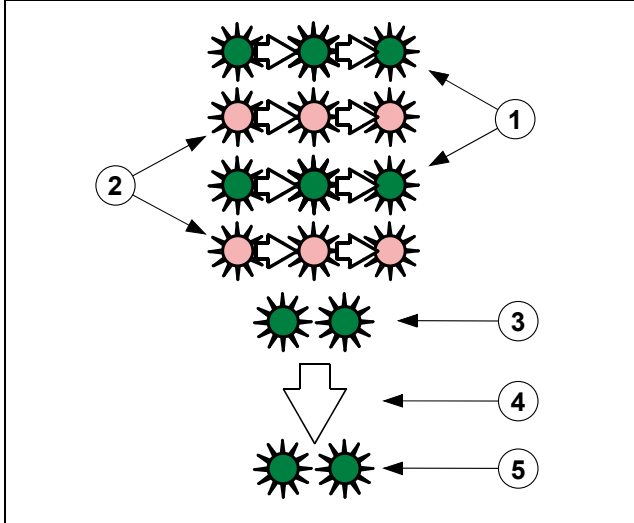

- 1 - Sequence of three green LED flashes
- 2 - Sequence of three red LED flashes
- 3 - Two green LED flashes to leave sensitivity mode
- 4 - 8 seconds later
- 5 - Two green LED flashes to return to normal operation

1.7 Flash rate and trouble indication

A unit with CleanMe activated double flashes (two flashes within a half second of each other) every eight seconds at the same rates as a normal detector. A normally operating unit flashes every eight seconds. If a detector is in a trouble condition due to a dirty lens or a sensor malfunction, it single or double flashes every four seconds, and the CleanMe trouble signal if enabled, is sent.



If CleanMe is selected and a non-CleanMe panel monitors the detectors when the CleanMe signal is sent to the panel, it considers the signal an alarm.

1.8 Electrical supervision

When the F220-B6 Series Bases are properly installed, tamper protection is provided by IN/OUT wiring of the positive power line. The control panel initiates a trouble signal when a detector is removed from its base. The control panel supervises two-wire systems. An EOL power supervision device, such as an D275 or an F220-B6E Power Supervision Base and an EOL resistor as specified by the control panel manufacturer, supervises a four-wire system.

2.0 Product family description

Table 3: Product Family Description

F220-P	Photoelectric smoke detector only, requires base.
F220-PTH	Photoelectric smoke detector w/integral 135°F (57°C) heat sensor, requires base
F220-PTHC*	Photoelectric smoke detector w/integral 135°F (57°C) heat sensor and CO enhanced smoke detection, requires base.
F220-PC*	Photoelectric smoke detector with CO enhanced smoke detection, requires base.
F220-B6	Base only, two-wire
F220-B6C	Base only, four-wire, Form C Auxiliary relay
F220-B6R	Base only, four-wire, Form A only
F220-B6E	Base only, for power supervision, four-wire, EOL relay and Form A fire contacts
F220-B6RS	Base only, four-wire with sounder and Form A fire contact
F220-135	Electronic heat detector 135°F (57°C), fixed temperature/rate-of-rise, requires base
F220-135F	Electronic heat detector 135°F (57°C), fixed temperature only, requires base
F220-190F	Electronic Heat Detector 190°F (88°C), fixed temperature only, requires base
D275	EOL supervision module for four-wire systems
DRA-5	Remote alarm indicator

* The F220PC and F220PTHC detect CO as a component of a fire. Do not use the F220PC and F220PTHC as CO detectors.

2.1 Compatible control panels

Two-wire: See *Technical Service Note* (P/N: 4998148185).



Bosch Security Systems makes no claim written, oral, or implied that the F220 Series Smoke Detectors work with any two-wire control panels except those specified in the Base Compatibility chart in *Technical Service Note* (P/N: 4998148185).

Four-wire: Compatible with all UL Listed four-wire control panels. Refer to the manufacturer's *Installation Instructions* for proper EOL resistor selection.

If using the optional DRA-5 Remote Alarm Indicator, connect the positive (red) lead to terminal b1 and the negative lead (white) to terminal c.

Figure 5: Remote alarm indicator

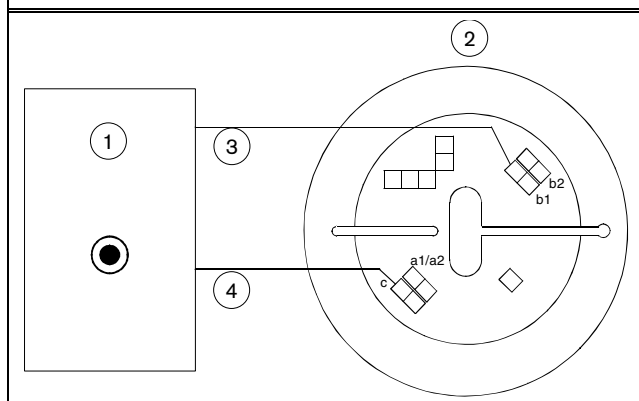

- 1 - DRA-5 remote alarm indicator
- 2 - Two-wire detector base
- 3 - Red wire (b1)
- 4 - White wire (c)

4.2 Four-wire detector wiring information



One D275 per loop is required when using the F220-B6RS base.

Terminal Connections: Do not twist or loop the wires around the terminals. In/Out wires for terminal connection must be cut, stripped, and inserted as individual ends.

EOL Resistors: Use the EOL resistors supplied or specified by the control panel manufacturer. This also applies to the D275 Module.

D275 Power Supervision Relay: When used with 12 VDC systems, connect the red wire to Terminal b1 on the last base in the run. The yellow wire remains unconnected. For 24 VDC systems, connect the yellow wire to Terminal b1. The red wire remains unconnected. (See Figure 6).



One D275 or F220-B6E per loop is required when using the F220-B6R/B6C bases.

Figure 6: F220-B6R in a four-wire configuration with D275

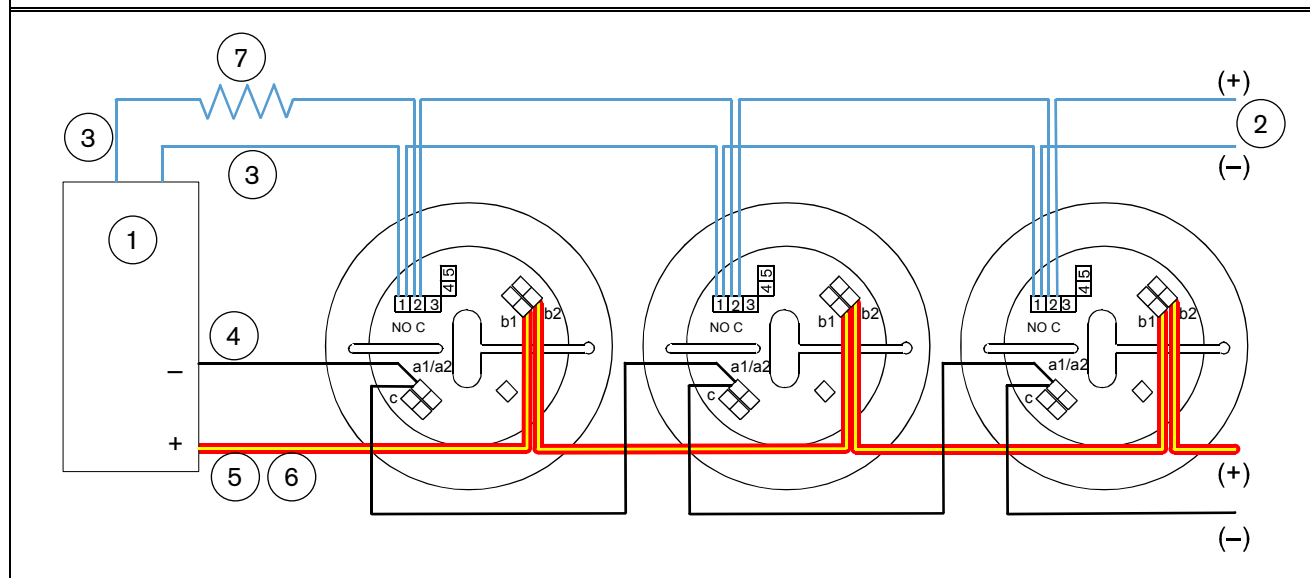

- 1 - D275
- 2 - Alarm loop (Terminals 1 and 2)
- 3 - Blue wire (Terminal 1 and EOLR, D275)
- 4 - Black wire (D275, Common)
- 5 - Yellow wire (D275 for 24 V systems)
- 6 - Red wire (D275 for 12 V systems)
- 7 - EOL resistor

3.0 Mounting

3.1 Mounting the F220-B6RS/B6/B6R/B6C/B6E Detector Bases

1. Follow NFPA-72 guidelines for mounting locations.
2. Release the base skirt from the mounting base. Use a screwdriver on the outer edge to release two of the four fixing clamps.
3. Pre-run all system wiring.
4. Mount the base using the two oblong mounting holes. Fits 4 in (10 cm) square, AB, and single gang trim plate.
5. Tighten the base to the mounting surface. Do not over tighten.



Depending on local regulations, you can surface mount the bases using anchors, mollies, or wing nuts, or you can mount directly to 4 in (10 cm) octagonal electrical boxes and single gang switch boxes.



The electrical box must be large enough to accommodate the number and size of conductors specified by the National Electrical Code or any local Authorities Having Jurisdiction (AHJ).

4.0 Wiring information

4.1 Two-wire Detector Wiring Information

Table 4: 2-wire Terminal Functions (see Figure 4)

DC-IN/OUT	a1/a2
DC + IN	b1
DC + OUT	b2
Remote LED output	c



For easy wiring, the EOL resistor connections b1 and b2 are exchanged on the last detector.

Figure 4: F220-B6 in a Two-wire configuration

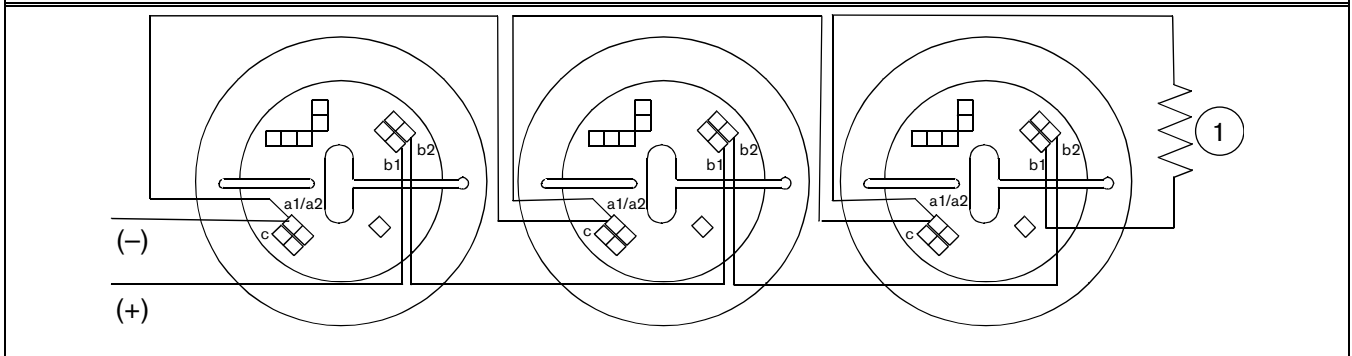

1 - EOL resistor

4.6 Wiring the F220-B6RS

The alarm loop relay (Terminals NO and C) is a Form A relay rated 0.5 A use at 60 VDC

Table 8: F220-B6RS terminal functions
(see *Figure 12*)

DC-IN/OUT	a1/a2
DC + IN	b1
DC + OUT	b2
Remote LED output	c
Alarm Contact	NO, Form A contact (Terminal 1)
Alarm Relay	C, Form A contact (Terminal 2)
Interconnect Feature	INT, SYNC (see <i>Figure 12</i>) Terminal 3
Auxiliary DC supply	SEP+ (Terminal 4)
Auxiliary DC supply	SEP- (Terminal 5)
If using external supply switches, 1 and 2 must be in the OFF position.	

4.7 135/135F/190F/P/PTH/PC/PTHC Heat/Photoelectric Smoke Detectors

1. Mount and wire the base according to its instructions.
2. Attach the base skirt by aligning the four hardware keys, or turn the base skirt slowly clockwise until it rests in place. Press firmly to latch it onto the fixing clamps (See *Figure 10*).
 - Use the tamper tab (locking bar) to prohibit detector removal as follows:
3. The snap off locking bar (X) is part of the base molding. Shift the locking bar (X) into the position shown in *Figure 9* to engage it.
4. Install the detector by lining up the LED on the detector head with the bar on the base skirt and turning clockwise. When the LED lines up with the "T" on the base skirt the detector is secure (see *Figure 11*).

Figure 9: Activating the locking bar (X)

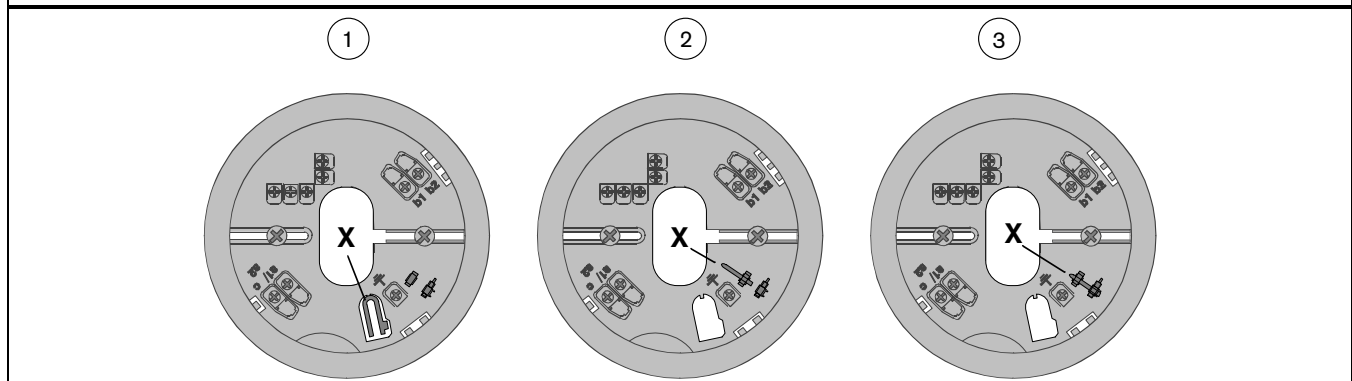

1 - Locking bar (X) prior to removal

2 - Locking bar (X) mounted but inactive

3 - Lock activated



The detector skirts and heads are keyed. Do not force onto the bases.

Figure 10: Attaching the base skirt

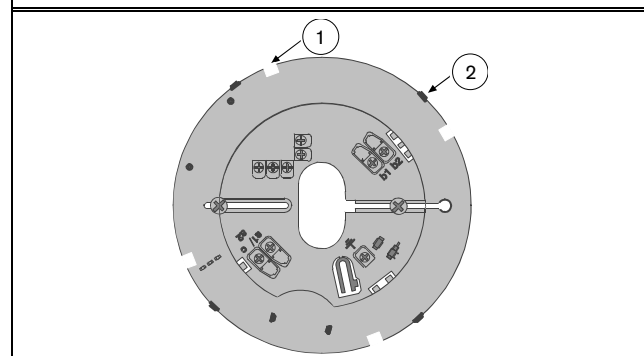

1 - Hardware keying (four places)

2 - Snap detail (four places)

Figure 11: Mounting the detector on the base skirt

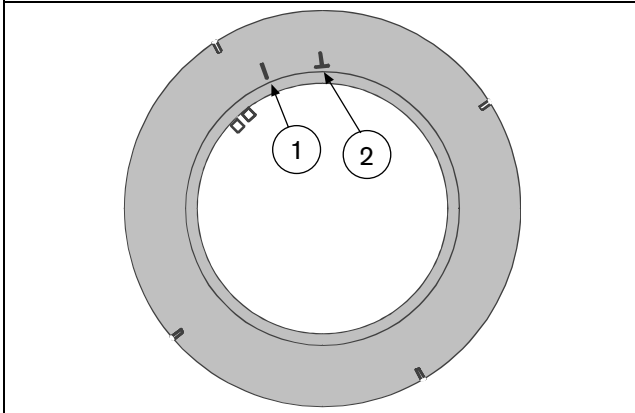

- 1 - Bar (line up with LED on detector head)
- 2 - "T" Mark

5.0 F220-B6RS Features

5.1 Configuration

On the sounder base is a four position DIP switch.

Table 9: F220-B6RS Sounder Base Configuration

Position 1 and 2 (separately controlled sounder) switches off	Control panel NAC circuit power is applied to the base to Terminals 4(+) and 5(-). The sounder follows the configuration of the NAC. See the control panel manual for NAC configuration.
Positions 1 and 2 switches on	Power is taken from the head to activate the sounder. Sounder output configured by DIP Switches 3 and 4.
Position 3 on	Code 3 signal.
Position 4 on	March Time signal.
Positions 3 and 4 off	Steady signal.

Figure 12: F220-B6RS 4-wire configuration with D275 (tandem connection)

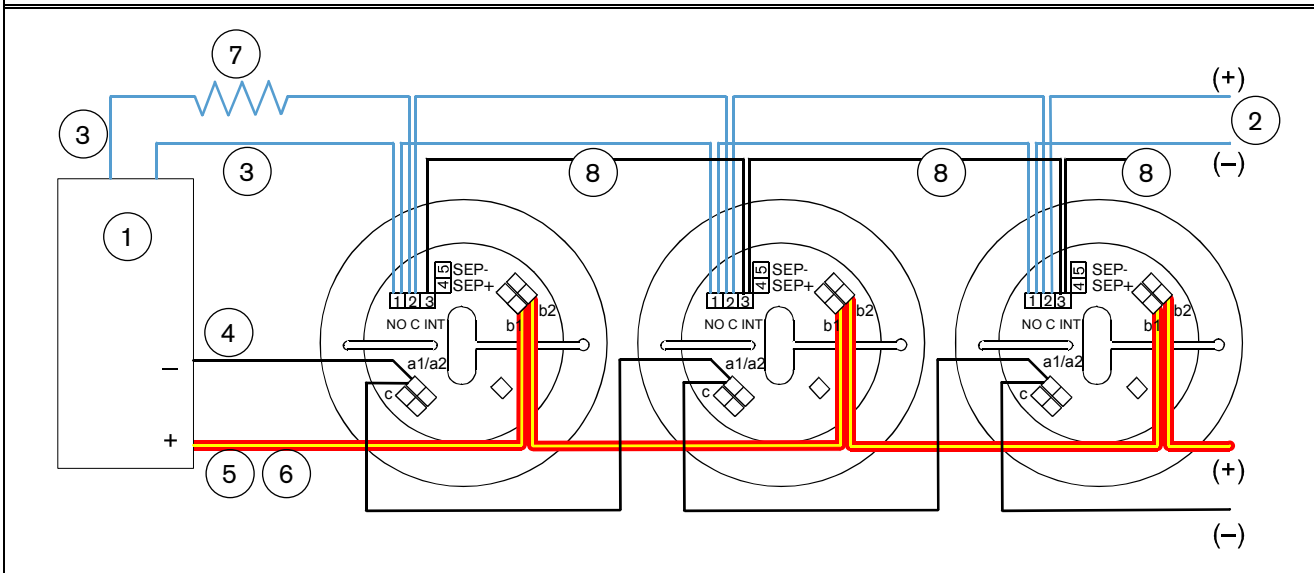

- 1 - D275
- 2 - Alarm loop (Terminal 1 and 2)
- 3 - Blue wire (D275, Terminal 1 and EOLR)
- 4 - Black wire (D275, Common)
- 5 - Yellow wire (D275 for 24 V systems)
- 6 - Red wire (D275 for 12 V systems)
- 7 - EOL resistor
- 8 - Tandem connection (up to five maximum)

5.2 Interconnect feature

When the sounder is powered from the head, you can connect up to five detectors by a common wire on Terminal 3. All sounders within the group activate together. Set all units for the same sounder type on Switches 3 and 4, otherwise all detectors sound the pattern of the originating detector.



To ensure interconnected units can alarm, the line load after the last detector must not exceed 10 mA so.

These restrictions do not apply to reverse polarity activation.

**Table 10: Interconnected Units (five units total)
Maximum Wire Length**

Wire size	Wire length
18 AWG (1.2 mm)	300 ft (91 m)
16 AWG (1.5 mm)	450 ft (137 m)
14 AWG (1.8 mm)	750 ft (229 m)



Up to five interconnected units activate per circuit. If more than five units activate, only individual detectors are guaranteed to activate the correct output pattern. Tandem units cannot activate the correct output pattern.

6.0 Testing the installation

1. Check the wiring from the control panel to the last head on each run for proper polarity and continuity.
2. Make sure each run terminates with an EOL resistor as specified by the control panel manufacturer.
3. Make sure four-wire runs terminate at EOL Modules or F220-B6E bases.
4. Apply power to the system. Check for alarms and troubles.
5. Note which detectors alarmed (if any), and shut down the system.
6. Remove these detectors from their bases and recheck the bases for proper wiring.
7. If the problem persists, determine if the problem is caused by the detector or the base.
8. Replace the affected detectors or swap them with known good units.
9. If a system alarm occurs with no detector alarms present, remove all detectors and check the wiring at each base.
10. Closely check the wiring of each EOL resistor and EOL module.
11. When the system is alarm free, check each detector to ensure that the green LED indicator flashes approximately every eight seconds. This verifies the detector is receiving power and operating properly.



If the heat detector LED flashes at a four second rate, the detector is either cold, out of sensitivity range, or defective. If the smoke detector LED flashes at a four second rate the detector is out of sensitivity range or defective.

12. Test each detector to ensure it causes a control panel alarm. Reset the control panel after each test.

To alarm the F220-135/135F/190F Detectors either:

- Place a magnet horizontally against the “T” and hold it there for three consecutive LED flashes (see *Figure 1, #4*). This activates an internal reed switch thereby sending an alarm signal.

or

- Expose the thermistor (see *Figure 1, #3*) to a heat source such as a hair dryer or a shielded heat lamp. Expose the thermistor until the detector alarms and the alarm LED lights.

To alarm the F220-P/PTH/PC/PTHC Detectors either:

1. Place a magnet horizontally against the “T” and hold it there for three consecutive LED flashes (see *Figure 1, #4*). This activates an internal reed switch thereby sending an alarm signal.

or

Use a UL Listed aerosol smoke detector tester to simulate an alarm. Follow the instructions provided with the aerosol smoke detector tester.



When a detector alarms, the red LED indicator activates and latches into the ON position. Clear the alarm before proceeding to the next detector.

2. Reset the detector by momentarily removing power.
3. Check the load on the alarm loop by measuring the voltage across each EOL resistor. This voltage should equal or exceed the minimum specified by the control panel manufacturer.

6.1 CO detector testing

Removing the detector or resetting the detector's power places the detector in a special test mode for the next 15 minutes. If over 35 ppm of CO is applied to the detector within this 15-minute period, the detector alarms.



The F220PC and F220PTHC detect CO as a component of a fire. Do not use the F220PC and F220PTHC as CO detectors.

7.0 Maintenance



Notify all concerned parties before any maintenance or testing of the fire alarm system, and after completion of these activities.

- At least once a year vacuum or clean/dry the external part of the detector with compressed air. Pay particular attention to the screens in dusty areas or heavy insect activity.
- To clean the chamber, use a can of clean compressed air. Place the tube or needle valve through the ChamberMaid valve in the bottom of the detector (see *Figure 1*, #5).



Shorten the plastic tube that comes with the compressed air to about 2 in (5 cm). The compressed air (such as TECHSPRAY® ENVI-RO-TECH™ DUSTER) is available at office and alarm supply stores.

- Do not paint the detectors. Paint or other foreign matter covering the thermistor or LED can prohibit detection.

8.0 Periodic testing

Keeping the detector calibrated is necessary for proper operation. Depending on local regulations, calibration testing can be required more than once a year. NFPA 72 recommends performing calibration tests at installation, then every other year. Perform functional testing yearly.



Notify all concerned parties before any maintenance or testing of the fire alarm system, and upon completion of these activities.

Test the calibration (to meet NFPA) using either the magnet test or measuring the calibration with a calibrated product from No Climb Products Ltd. Quickly determine the calibration by a visual inspection of the detector's LED (see *Section 9.0 Visual check*). These tests confirm whether or not the detector is within its factory marked calibration range.

9.0 Visual check

These detectors includes the Chamber Check Automatic Trouble Indicator, which verifies that the detector's calibration is within the factory listed range. You can meet the NFPA guidelines for sensitivity testing by visually inspecting the detector and checking the flash rate of the LED. If the calibration is out of range for more than 24 hours, the green LED on the detector begins to flash approximately once every four seconds. The LED flashes approximately once every eight seconds when the detector operates normally.



Perform the visual check before resetting power. After a reset the trouble indicators clear for 70 seconds. After 70 seconds, if the detector is in a trouble condition, trouble indications begin again

10.0 Specifications

Table 11: F220-135/-135F/-190F Heat Detectors, F220-P/-PTH/-PC/-PTHC Photoelectric Smoke Detectors and F220-B6RS/C/R/E Smoke Detector Base	
Technical Data	
Operating Temperature	+32°F to 100°F (0°C to 38°C)
Relative Humidity (non-condensing) (F220-P)	0% to 95%
Rate of Rise (F220-135)	≥ 15°F/min (9°C/min)
Detector Power Requirements	
Operating Voltage	8.5 VDC to 32 VDC
Maximum RMS Ripple	25 percent of DC input (V _{min} > 8.0 VDC)
Startup Current	120 µa maximum
Standby Current	90 µa use at 12 VDC 100 µa use at 24 VDC 120 µa maximum use at 32 VDC
Power up Time	22 second maximum
Alarm current for all F220 Detectors	20 mA minimum use at 8.5 VDC 35 mA maximum use at 32 VDC
F220-B6 (2-wire)	8.5 to 32.0 VDC
F220-B6 (R, C, E, RS) (4-wire)	10.0 to 30.0 VDC
Alarm Current (only base current, head current excluded)	
F220-B6C	31 mA use at 12 VDC 35 mA use at 24 VDC 40 mA maximum use at 30 VDC
F220-B6R	13.5 mA use at 12 VDC 16.5 mA use at 24 VDC 19 mA maximum use at 30 VDC
F220-B6E	25 mA use at 12 VDC 30 mA use at 24 VDC 34 mA maximum use at 30 VDC
F220-B6E Standby Current	16 mA maximum use at 30 VDC
F220-B6RS	25 mA use at 12 VDC 30 mA use at 24 VDC 35 mA maximum use at 30 VDC
(current at separate positive/negative for separately powered sounders)	
Alarm Current (including sounder, steady out and relay)	
F220-B6RS with Relay and Sounder (Steady Out Signal)	40 mA use at 12 VDC 45 mA use at 24 VDC 50 mA maximum use at 30 VDC

Trademarks

- CleanMe is a trademark of GE Interlogix.
- ChamberMaid and Chamber Check are a trademarks of Bosch Security Systems
- TECHSPRAY is a registered trademark and ENVI-RO-TECH is a trademark of Tech Spray L.P.

Distribuição: Segurança Industrial Equipamentos
Fone/Fax: (41) 4063-9687
cml@segind.com.br - segindbr@hotmail.com
www.segind.com.br